

U360LL

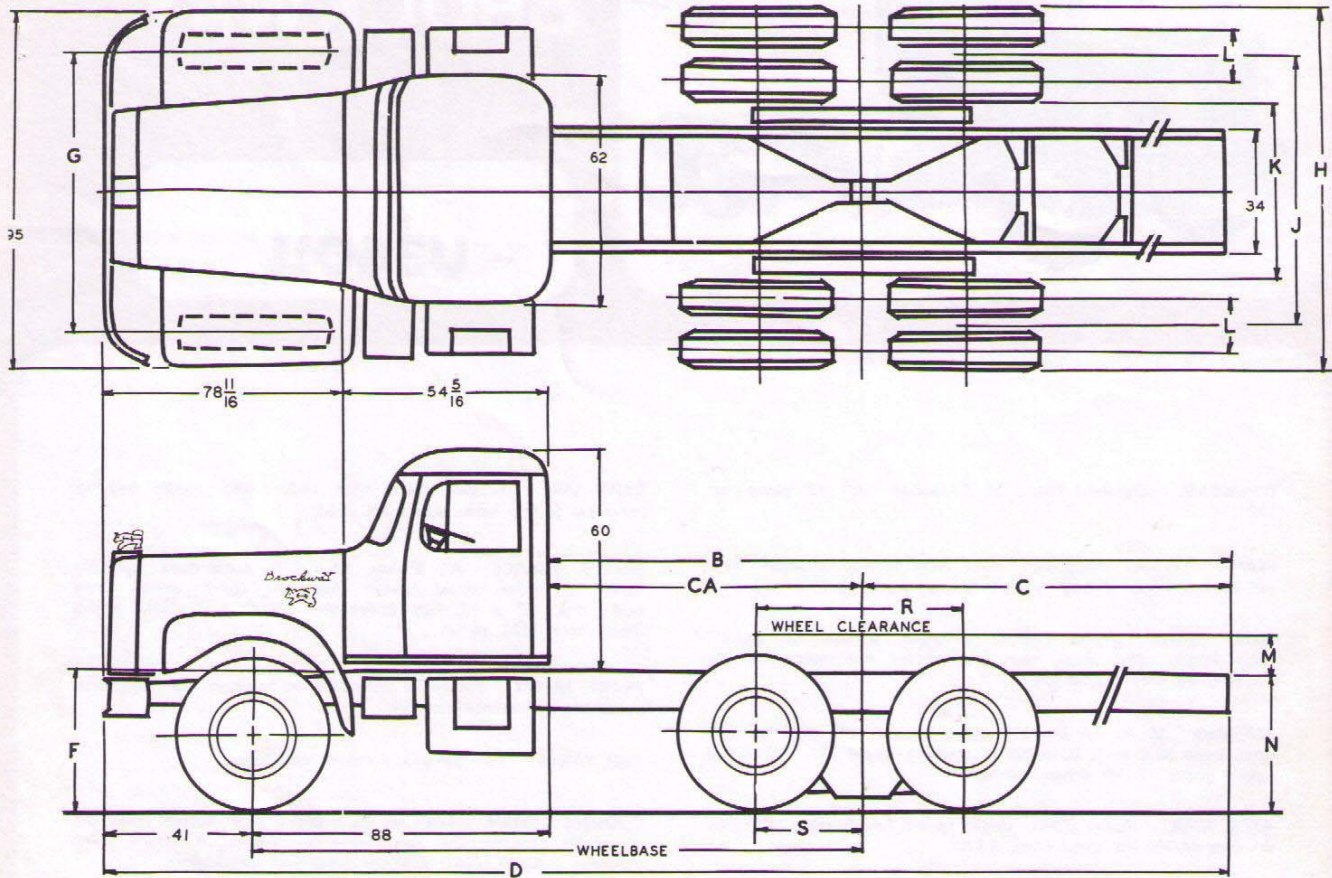

KEY TO SYMBOLS

- CA—Rear of cab to centerline of rear axle
- B—Rear of cab to rear end of frame
- C—Centerline of rear axle to rear end of frame
- D—Overall length
- G—Front axle tread
- J—Rear axle tread
- H—Width over rear tires
- K—Width inside rear tires
- L—Tire centerline spacing
- F—Frame height at centerline of front axle
- N—Frame height at centerline of rear axle
- M—Minimum frame to wheel house, with chains
- R—Tandem axle spacing

MODEL	TANDEM AXLE CARGO				
	WHEEL-BASE	CA	B	C	D
360	196	108	192	84	325
AXLE		R			
SSHD		54"			

TIRES	FRONT AXLE		REAR AXLE 10 ³ / ₄ x 3 ³ / ₈ x ³ / ₈ FRAME RAILS		
	MODEL	MODEL	MODEL		M
	FH901	SSHD			
	F		N		
	LIGHT	LOAD	LIGHT	LOAD	
10.00 x 20	39.8	38.0	48.5	47.1	6.8

360 SERIES CARGO—TANDEM AXLE

FRONT AXLE				REAR AXLE								
TIRES	MODEL	G		MODEL	J		H		K		L	
		SPOKE	DISC		SPOKE	DISC	SPOKE	DISC	SPOKE	DISC	SPOKE	DISC
10.00 x 20	FH901	79.8	78.9	SSHD	72.2	—	96.5	—	47.9	—	13.5	—