

359T

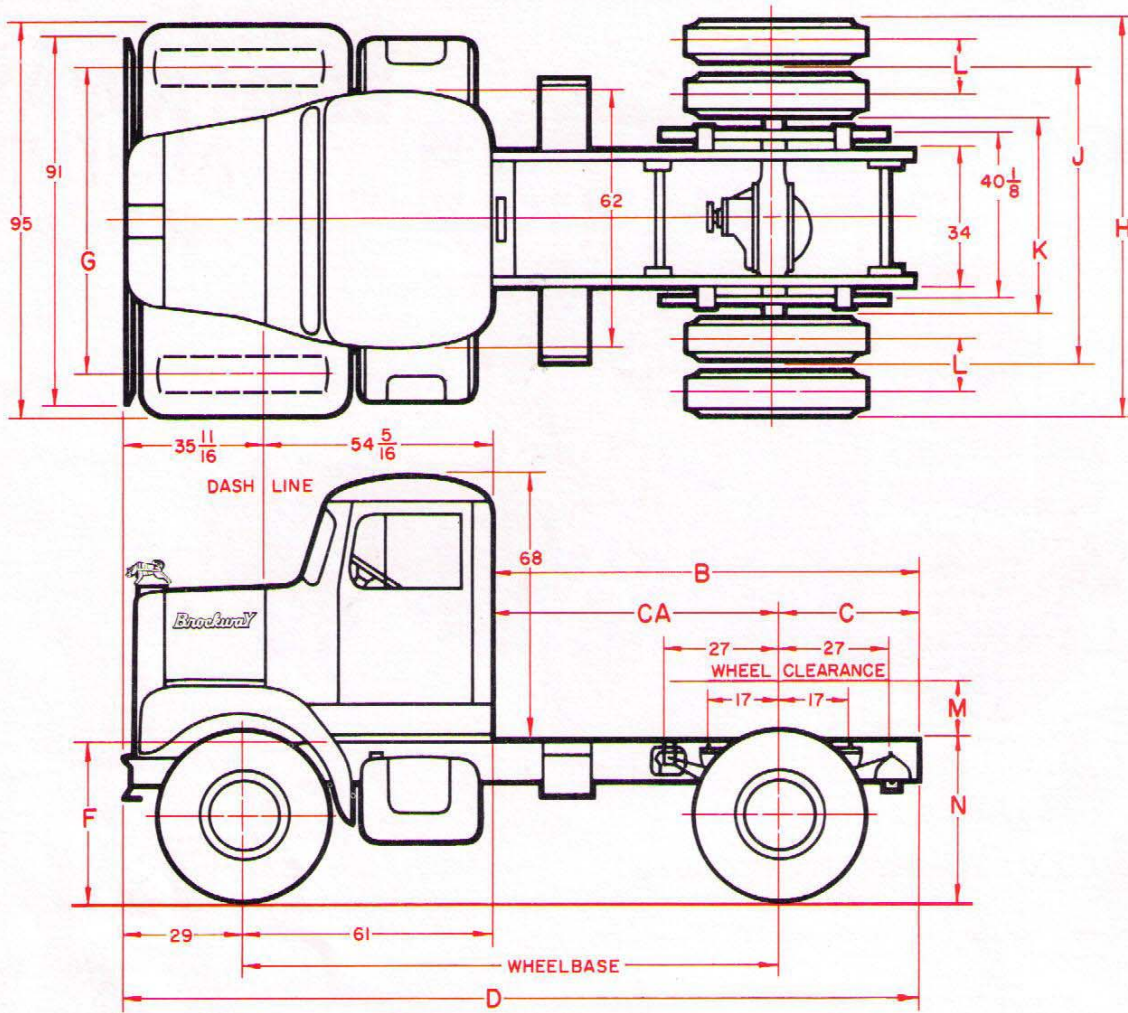

KEY TO SYMBOLS

- CA—Rear of cab to centerline of rear axle
- B—Rear of cab to rear end of frame
- C—Centerline of rear axle to rear end of frame
- D—Overall length
- G—Front axle tread
- J—Rear axle tread
- H—Width over rear tires
- K—Width inside rear tires
- L—Tire centerline spacing
- F—Frame height at centerline of front axle
- N—Frame height at centerline of rear axle
- M—Minimum frame to wheel house, with chains

| MODEL | SINGLE AXLE TRACTOR | | | | |
|-------|---------------------|----|-----|----|-----|
| | WHEEL-BASE | CA | B | C | D |
| 359 | 133 | 72 | 106 | 34 | 196 |

| TIRES | FRONT AXLE | | REAR AXLE** 9 x 3 1/4 x 1/4 FRAME RAILS | | |
|------------|------------|------|---|------|------|
| | MODEL | | MODEL | | |
| | FF921 | | 19220 | | |
| | F | | N | | M |
| | LIGHT | LOAD | LIGHT | LOAD | |
| 10.00 x 20 | 38.8 | 37.0 | 40.6 | 37.6 | 12.0 |

** NOTE: For 10 3/4 x 3 3/8 x 3/8 Frame Rail, add 1.8 to "N" dimension and subtract 1.8 from "M" dimension.

TRACTOR SINGLE AXLE

| FRONT AXLE | | | | REAR AXLE | | | | | | | | |
|------------|-------|-------|------|-----------|-------|------|-------|------|-------|------|------|------|
| TIRES | MODEL | G | | MODEL | J | | H | | K | | L | |
| | | SPOKE | DISC | | SPOKE | DISC | SPOKE | DISC | SPOKE | DISC | | |
| 10.00 x 20 | FF921 | 78.7 | 79.4 | 19220 | 72 | 72.4 | 96 | 96 | 47.8 | 48.6 | 13.5 | 13.1 |