

361T

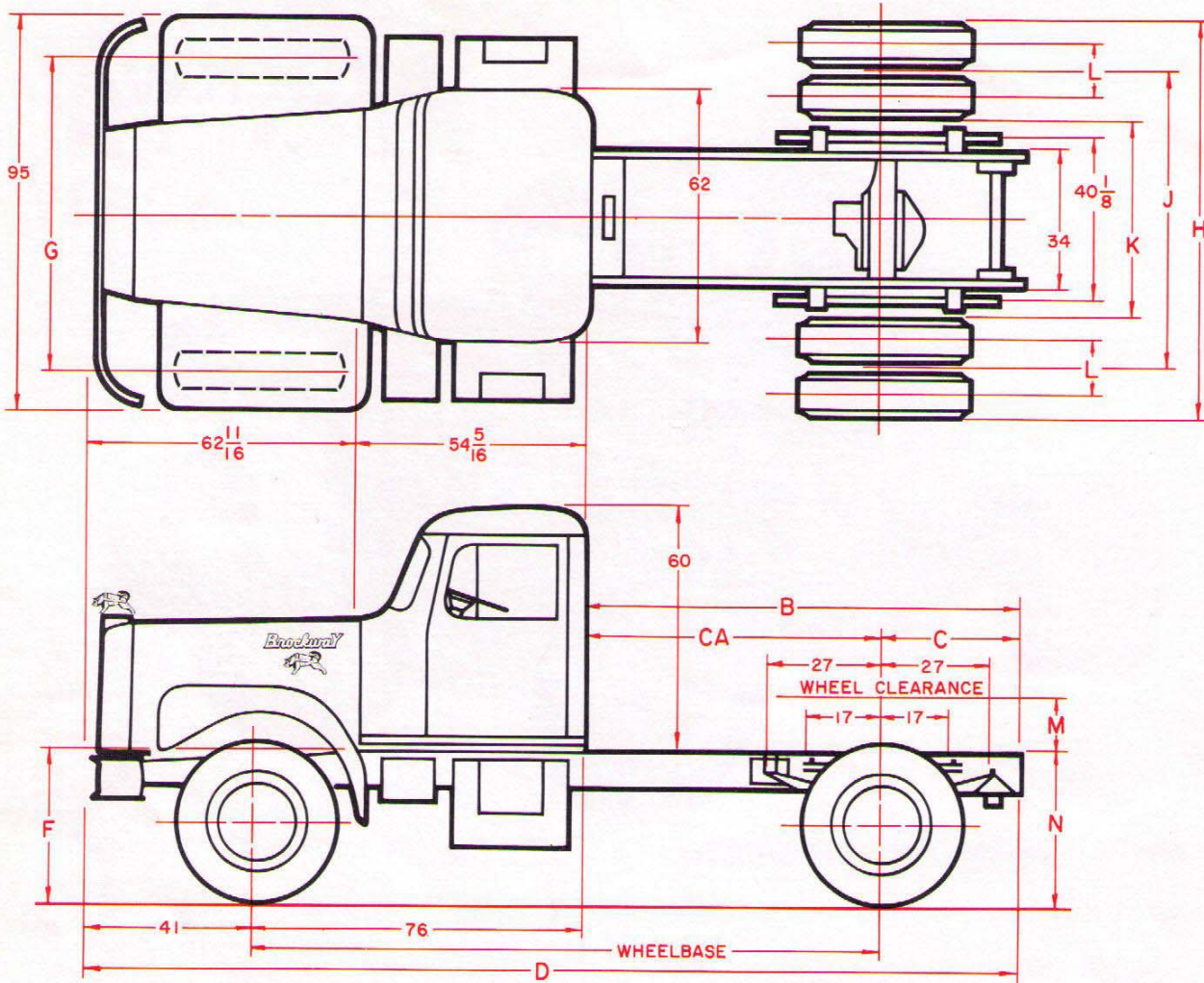

KEY TO SYMBOLS

- CA—Rear of cab to centerline of rear axle
- B—Rear of cab to rear end of frame
- C—Centerline of rear axle to rear end of frame
- D—Overall length
- G—Front axle tread
- J—Rear axle tread
- H—Width over rear tires
- K—Width inside rear tires
- L—Tire centerline spacing
- F—Frame height at centerline of front axle
- N—Frame height at centerline of rear axle
- M—Minimum frame to wheel house, with chains

SINGLE AXLE TRACTOR					
MODEL	WHEEL-BASE	CA	B	C	D
361	148	72	106	34	223

TIRES	FRONT AXLE		REAR AXLE** 9 x 3 1/4 x 1/4 FRAME RAILS		
	MODEL		MODEL		
	FF921		19220		
	F		N		M
	LIGHT	LOAD	LIGHT	LOAD	
10.00 x 20	40.3	38.5	40.6	37.6	12.0

** NOTE: For 10 3/4 x 3 3/8 x 3/8 Frame rail, add 1.8 to "N" dimension and subtract 1.8 from "M" dimension.

361 SERIES TRACTORS—SINGLE AXLE

FRONT AXLE				REAR AXLE								
TIRES	MODEL	G		MODEL	J		H		K		L	
		SPOKE	DISC		SPOKE	DISC	SPOKE	DISC	SPOKE	DISC		
10.00 x 20	FF921	78.7	79.4	19220	72	72.4	96	96	47.8	48.6	13.5	13.1